

ROSTA Tensioner Devices

**Maintenance-free tensioner systems for belt and chain drives
Easy to install – available in 7 standard sizes – wide range of
accessories available**



Customer Benefits from using ROSTA



SE



- Guarantees the lowest possible maintenance outlay
- Is tensioned "for life" (belts)
- Transmits a constant torque
- Gentle belt handling – longer service life

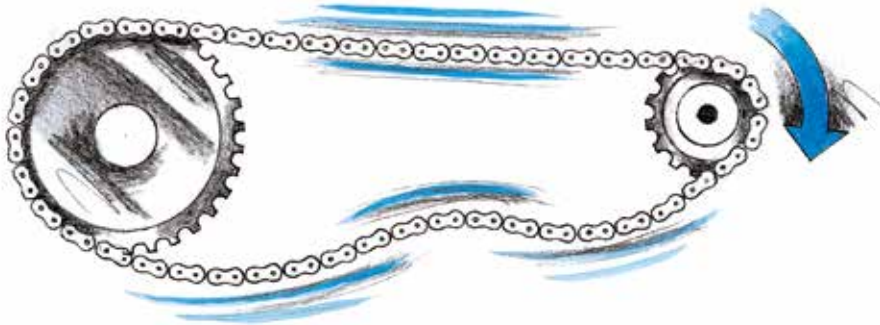

- Prevents the polygon effect in the slack side
- Increases the chain contact arc
- Excludes any jumping of the chain links
- Causes the slack side to run tautly and almost silently



SE-F



- Offers continuous contact pressure
- Compensates for wear on the scrapers
- Effectively dampens vibrations in the belt band
- Guarantee for clean conveyor belts



SE-W

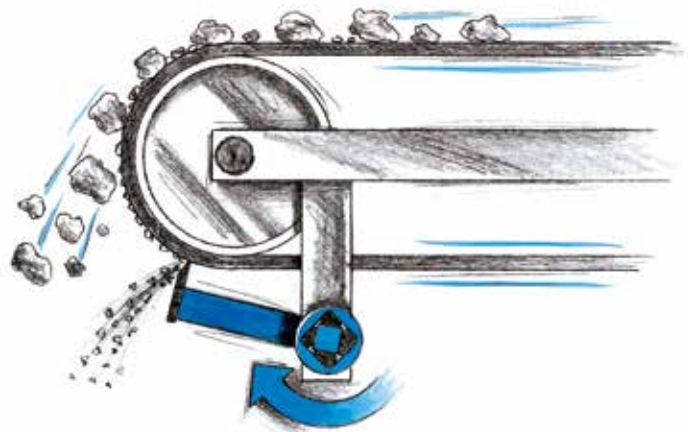

Tensioner Devices in Belt and Chain Drives

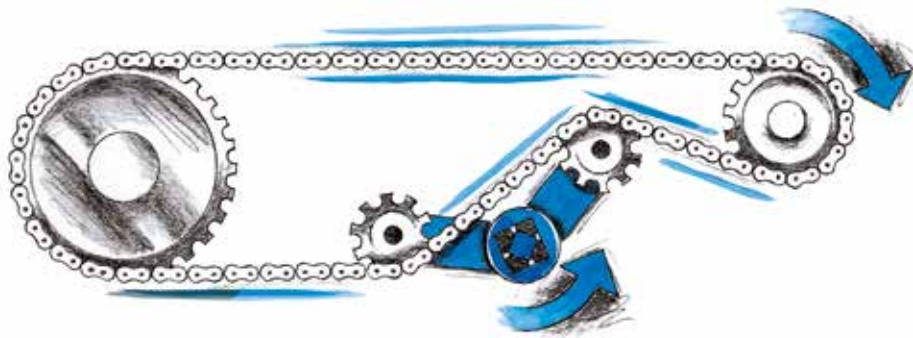

- Offers an extremely quiet chain run
- Reduces wear on rollers and bearings
- Effectively dissipates vibrations
- 3-fold slack compensation with "Boomerang®"



SE-FE



SE-B

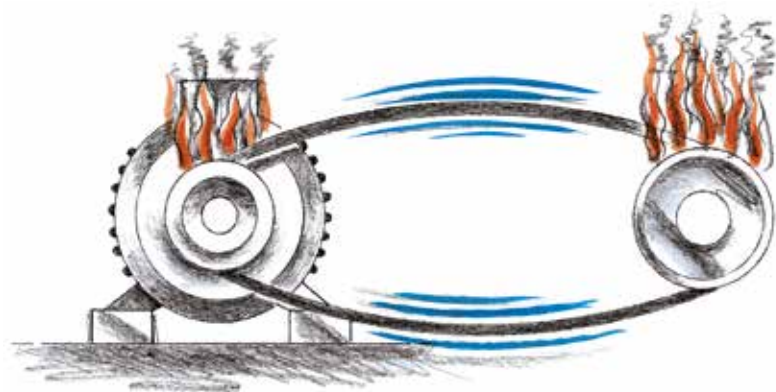

- Compensates for belt lengthening
- Prevents excessive slippage and over-heating
- Offers constant torque transfer
- Guarantees longer belt lifetimes



SE-I

- Offers an exactly defined contact pressure
- Accurately transports workpieces
- Maintenance-free and long lasting
- Is a cost-effective alternative to pressure cylinders



SE-G

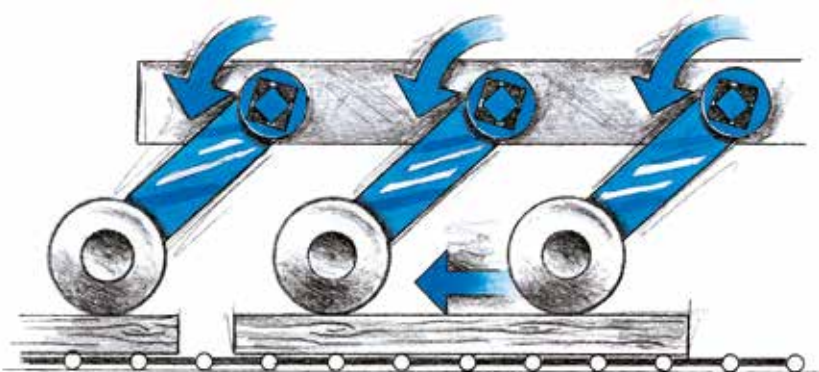

Selection table

	Identification	Characteristics	Working temperature	Details	Illustration	
Standard tensioner devices	SE Standard component	Steel parts ROSTA blue painted. Rubber quality Rubmix 10.	Housing and inner core made out of steel.	-40° to +80° C	Page 4.6	
	SE-G Oil resistant	Steel parts galvanized. Rubber quality Rubmix 20. Marked with yellow dot.		-30° to +90° C	Page 4.6	
	SE-W Heat resistant	Steel parts ROSTA blue painted. Rubber quality Rubmix 40. Marked with red dot. Tension force 40% less than SE.		-35° to +120° C max.	Page 4.6	
Additional tensioner devices	SE-R Reinforced lever arm	Arm and inner core especially welded for use on combustion engines and compressors. Steel parts ROSTA blue painted. Marked with white ring.	Housing and inner core made out of steel, inserts Rubmix 10.	-40° to +80° C	Page 4.6	
	SE-I Stainless steel	For the use in food- and pharmaceutic industries. Material: GX5CrNi19-10. Exception: SE-I 40 made out of X5CrNi18-10.			Page 4.6	
	SE-B Boomerang®	For the tensioning of very long chain and belt drives (triple compensation). Steel parts ROSTA blue painted.			Page 4.7	
	SE-F Front mounting device	For installations on blind-hole frames (fixation from the front only). Steel parts ROSTA blue painted. Hex socket screw quality 12.9.			Page 4.7	
	SE-FE Front mounting device	For installations on blind-hole frames (fixation from the front only). Steel parts black painted. Hex socket screw quality 12.9. Especially designed for engine applications.			see page 4.7	Page 4.7
Accessories chain drives	Sprocket wheel set N	Allows accurate positioning of relevant chain track. Ball-bearings 2Z/C3, permanently lubricated.	-40° to +100° C	Page 4.8		
	Sprocket wheel N					
	Chain rider set P	For double sided use. Max. allowed chain speed 1.5 m/sec. Material: POM-H.	-40° to +100° C	Page 4.9		
	Chain rider P					
Accessories belt drives	Tensioning roller R	Material: PA 6. Ball-bearings 2Z/C3, permanently lubricated.	-35° to +100° C	Page 4.10		
	Tensioning roller light RL	Material: PA 6. Ball-bearings 2Z/C3, permanently lubricated.	-35° to +80° C	Page 4.10		

Further information to customized elements and installation examples as from page 4.12.



General technology

The ROSTA tensioners should be installed on a stiff, even and clean machine part by means of the central bolt. The frictional connection on flange is usually fully sufficient for final positioning. The positioning notch on flange can be used to assure the tensioner additionally on uneven and dirty surfaces by setting a roller-pin.

Tensioning force F

The tensioning force can be continuously adjusted. The max. pre-tensioning angle is +30° out of neutral position. Tensioning force table for types **SE / SE-G / SE-R / SE-F / SE-I** by using **hole-position "normal"** for sprocket-, rider- and roller fixation.

Size SE	Pre-tension $\leq 10^\circ$		Pre-tension $\leq 20^\circ$		Pre-tension $\leq 30^\circ$	
	F [N]	s [mm]	F [N]	s [mm]	F [N]	s [mm]
11	18	14	48	27	96	40
15	25	17	65	34	135	50
18	75	17	185	34	350	50
27	150	23	380	44	810	65
38	280	30	720	60	1500	88
45	520	39	1350	77	2650	113
50	740	43	2150	86	4200	125

SE-I 40: same tensioning force like SE 38.

SE-W: 40% lower tensioning force than standard versions (Rubmix 40 inserts).

SE-FE: see page 4.7

When fixing the sprockets, riders and rollers in arm-position "hard", tensioning force will increase on about 25%.

Mounting instructions

For further mounting instructions please consult the pages 4.9–4.11.

Z-configuration of sprockets or riders

If there is the need to install sprockets, riders or rollers on the outer arm-side of the tensioner, then the distance "Z" should be as little as possible to avoid a misalignment in element parallelism. Furthermore the pre-tension force should not exceed 50% of the capacity = max. pre-tension angle of $\sim 20^\circ$.

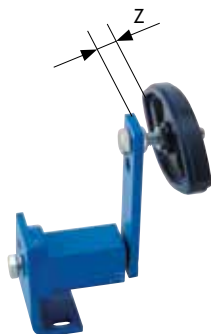

Use of SE-B Boomerang® tensioners

In very long chain and belt drives it was recommendable to install on the slack-side several tensioners, in order to compensate occurring elongation. The "Boomerang" with its bent double-arm equipped with two chain sprockets or a combination of grooved pulley and flat-roller (belt-drives) **offers a triple-compensation of chain and belt elongations, due to S-shape contact-arc.**

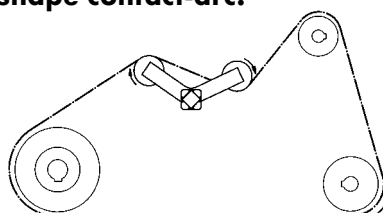

Tensioner mounting

Tighten the flange screw slightly. Grip the housing with flat-wrench and set needful pre-tension by rotating the housing in the required direction. Tighten the central screw according the above mentioned tightening moment M_A . **Position flat-wrench close by the flange-bottom.**

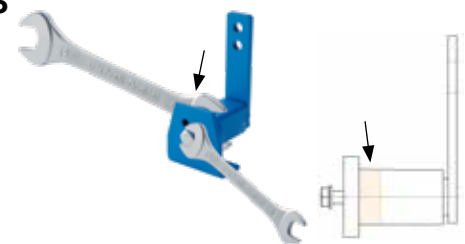

ROSTA
www.rosta.com

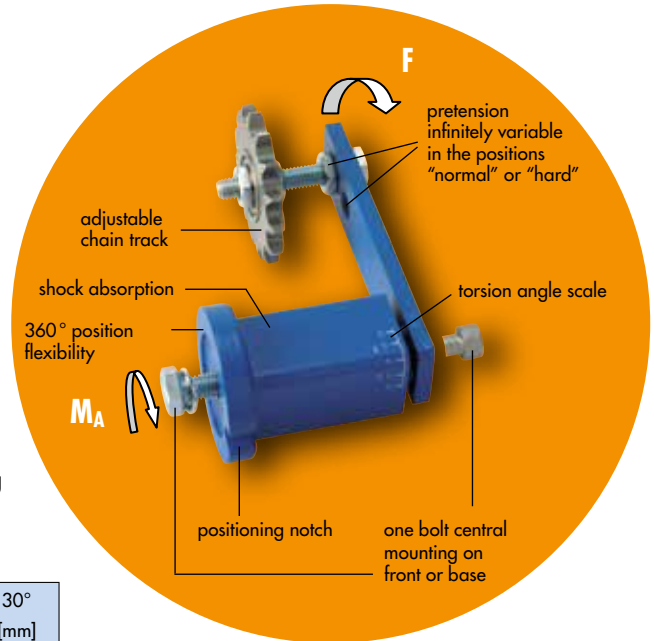

Tightening moment M_A for attachment screw

Table mentioning the tightening moment for the central screw (included in scope of delivery).

	Quality 8.8	Quality 12.9 for SE-F / SE-FE
M6	10 Nm	17 Nm
M8	25 Nm	41 Nm
M10	49 Nm	83 Nm
M12	86 Nm	145 Nm
M16	210 Nm	355 Nm
M20	410 Nm	690 Nm
M24	750 Nm	

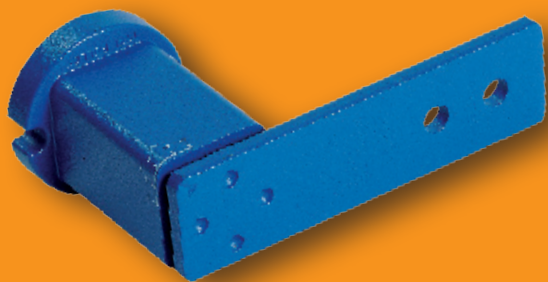

Tensioner Devices

Type SE/SE-G/SE-W

Type SE-R

Type SE-I

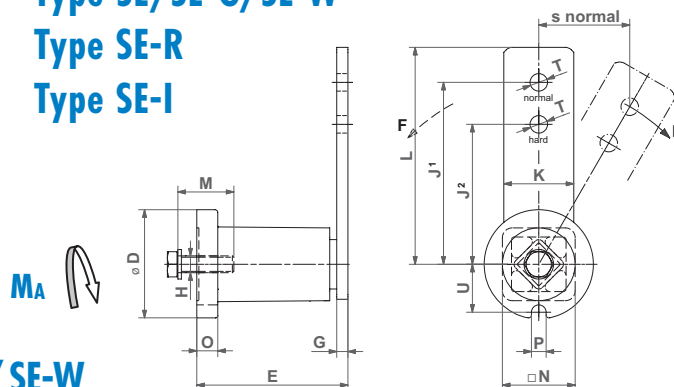

Standard Tensioner Devices Types SE / SE-G / SE-W

Type	Art. No.	D	E	G	H	J ¹	J ²	K	L	M	N	O	P	T	U	Weight [kg]
SE 11 SE 11-G	06 011 001 06 013 201	35	51 ⁺¹ -0.5	5	M6	80	60	20	90	20	22	6	8	8.5	16.5	0.2
SE 15 SE 15-G SE 15-W	06 011 002 06 013 202 06 015 002	45	64 ⁺¹ -0.5	5	M8	100	80	25	112.5	25	30	8	8.5	10.5	20.8	0.4
SE 18 SE 18-G SE 18-W	06 011 003 06 013 203 06 015 003	58	79 ^{+1.5} -0.5	7	M10	100	80	30	115	30	35	10.5	8.5	10.5	25.3	0.6
SE 27 SE 27-G SE 27-W	06 011 004 06 013 204 06 015 004	78	108 ⁺² -0.5	8	M12	130	100	50	155	40	52	15	10.5	12.5	34.3	1.7
SE 38 SE 38-G SE 38-W	06 011 005 06 013 205 06 015 005	95	140 ⁺² -0.5	10	M16	175	140	60	205	40	66	15	12.5	20.5	42.0	3.6
SE 45 SE 45-G SE 45-W	06 011 006 06 013 206 06 015 006	115	200 ⁺³ -1	12	M20	225	180	70	260	50	80	18	12.5	20.5	52.0	6.4
SE 50 SE 50-G SE 50-W	06 011 007 06 013 207 06 015 007	130	210 ⁺³ -1	20	M24	250	200	80	290	60	87	20	17	20.5	57.5	9.0

SE-R Tensioning element with strengthened tensioning arm

Type	Art. No.	D	E	G	H	J ¹	J ²	K	L	M	N	O	P	T	U	Weight [kg]
SE-R 15	06 011 702	45	64 ⁺¹ -0.5	5	M8	100	80	25	112.5	25	30	8	8.5	10.5	20.8	0.4
SE-R 18	06 011 703	58	79 ^{+1.5} -0.5	7	M10	100	80	30	115	30	35	10.5	8.5	10.5	25.3	0.6

SE-I Tensioning element made out of stainless steel, INOX

Type	Art. No.	D	E	G	H	J ¹	J ²	K	L	M	N	O	P	T	U	Weight [kg]
SE-I 15	06 071 111	45	64 ⁺¹ -0.5	5	M8	100	80	25	112.5	25	30	8	8.5	10.5	20.8	0.4
SE-I 18	06 071 112	58	79 ^{+1.5} -0.5	7	M10	100	80	30	115	30	35	10.5	8.5	10.5	25.3	0.7
SE-I 27	06 071 113	78	108 ⁺² -0.5	8	M12	130	100	50	155	40	52	15	10.5	12.5	34.3	2.1
SE-I 38	06 071 114	95	140 ⁺² -0.5	10	M16	175	140	60	205	40	66	15	12.5	20.5	42	4.3

Further product and performance datas on pages 4.4–4.5.

Tensioner Devices

Type SE-B Boomerang®

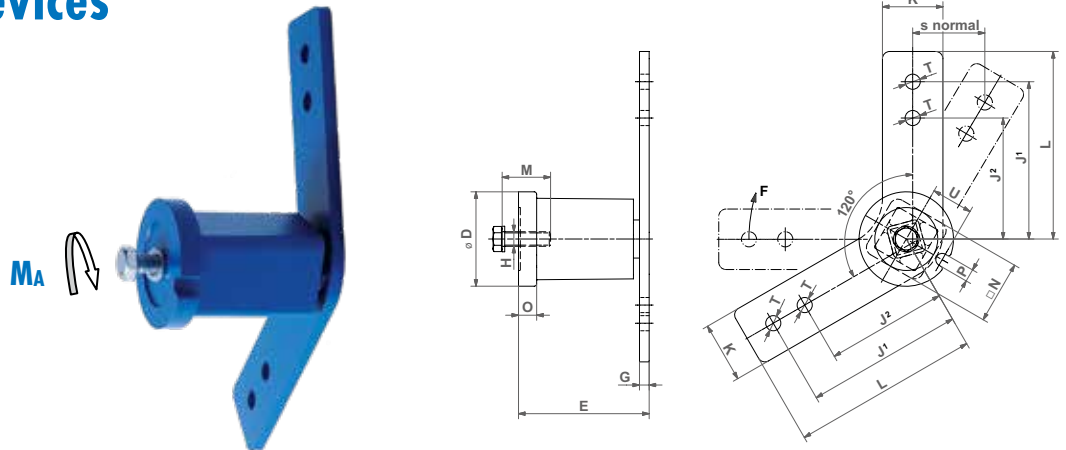

Type	Art. No.	D	E	G	H	J ¹	J ²	K	L	M	N	O	P	T	U	Weight [kg]	
SE-B 18	06 021 003	58	78	+1.5 -0.5	6	M10	100	80	30	115	30	35	10.5	8.5	10.5	25.3	0.8
SE-B 27	06 021 004	78	108	+2 -0.5	8	M12	130	100	50	155	40	52	15	10.5	12.5	34.3	2.1

Type SE-F

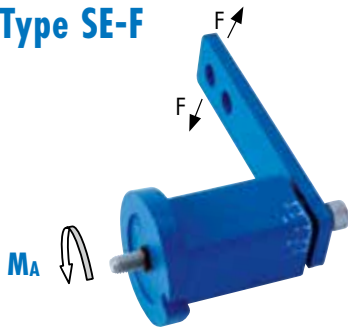

Type SE-FE

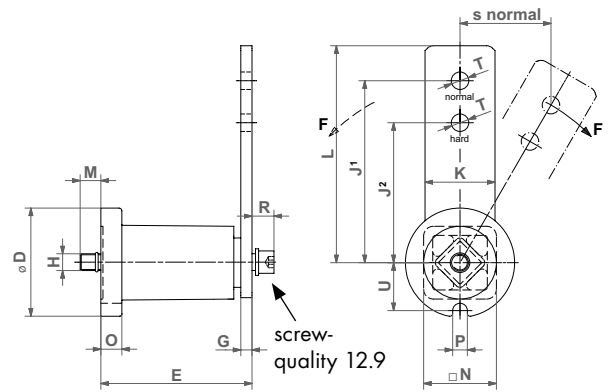
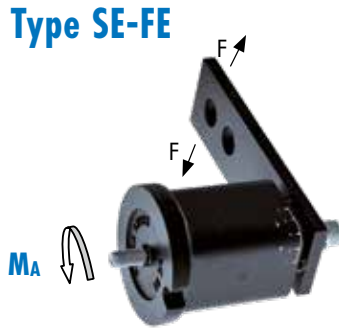

SE-F Tensioning element with front mounting

Type	Art. No.	D	E	G	H	J ¹	J ²	K	L	M ca.	N	O	P	R	T	U	Weight [kg]	
SE-F 15	06 061 002	45	64	+1 -0.5	5	M6	100	80	25	112.5	12	30	8	8.5	10	10.5	20.8	0.4
SE-F 18	06 061 003	58	79	+1.5 -0.5	7	M8	100	80	30	115	18	35	10.5	8.5	11	10.5	25.3	0.7
SE-F 27	06 061 004	78	108	+2 -0.5	8	M10	130	100	50	155	17	52	15	10.5	15	12.5	34.3	1.9
SE-F 38	06 061 005	95	140	+2 -0.5	10	M12	175	140	60	205	16	66	15	12.5	17	20.5	42.0	3.7
SE-F 45	06 061 006	115	200	+3 -1	12	M16	225	180	70	260	32	80	18	12.5	24	20.5	52.0	6.9
SE-F 50	06 061 007	130	210	+3 -1	20	M20	250	200	80	290	23	87	20	17	27	20.5	57.5	10.1

SE-FE Tensioning element with front mounting for engine (cooling compressors, fan drives)

Type	Art. No.	D	E	G	H	J ¹	J ²	K	L	M ca.	N	O	P	R	T	U	Weight [kg]	
new SE-FE 27	06 093 904	78	110	+2 -0.5	10	M10	130	100	50	155	16	52	15	10.5	15	12.5	34.3	2.1
new SE-FE 38	06 095 905	95	120	+2 -0.5	10	M12	145	110	60	175	35	66	15	12.5	17	22.0	42.0	3.1

Type	Art. No.	Rubber Type	Working temperature	SE-FE marked with	Pre-tension $\leq 10^\circ (J^1)$		Pre-tension $\leq 20^\circ (J^1)$		Pre-tension $\leq 30^\circ (J^1)$		Coating
					F [N]	s [mm]	F [N]	s [mm]	F [N]	s [mm]	
new SE-FE 27	06 093 904	Rubmix 20	-30°C to +90°C	yellow dot	150	23	380	44	810	65	RAL9005 (black) water-soluble paint thickness 40–80 µm
new SE-FE 38	06 095 905	Rubmix 40	-35°C to +120°C max.	red dot	170	25	425	50	870	73	

Further product and performance datas on pages 4.4–4.5.



Sprocket wheel set type N

Sprocket wheel set type N

Sprocket wheel type N

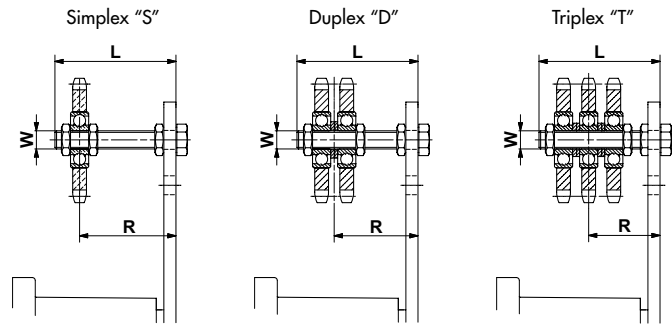

Roller chain		Type	Art. No.	Number of teeth	W	L	Torque hex nut 0.5 d [Nm]	Adjusting range track R	Size SE	Weight [kg]
ANSI	DIN 8187									
Simplex "S"										
35	ISO 06 B-1	N3/8"-10 S	06 510 001	15	M10	55	20	22-43 / 23-43	15/18	0.15
40	ISO 08 B-1	N1/2"-10 S	06 510 002	15	M10	55	20	23-44	18	0.20
50	ISO 10 B-1	N5/8"-12 S	06 510 003	15	M12	80	35	27-65	27	0.35
60	ISO 12 B-1	N3/4"-12 S	06 510 004	15	M12	80	35	27-65	27	0.55
60	ISO 12 B-1	N3/4"-20 S	06 510 005	15	M20	100	165	40-80	38	0.85
80	ISO 16 B-1	N1"-20 S	06 510 006	13	M20	100	165	40-80	38	1.25
100	ISO 20 B-1	N1 1/4"-20 S	06 510 007	13	M20	100	165	40-80 / 48-80	45 / 50	2.00
120	ISO 24 B-1	N1 1/2"-20 S	06 510 008	11	M20	140	165	40-120 / 48-120	45 / 50	2.35
Duplex "D"										
35	ISO 06 B-2	N3/8"-10 D	06 520 001	15	M10	55	20	27-39 / 28-39	15/18	2.00
40	ISO 08 B-2	N1/2"-10 D	06 520 002	15	M10	55	20	30-37	18	0.35
50	ISO 10 B-2	N5/8"-12 D	06 520 003	15	M12	80	35	36-57	27	0.60
60	ISO 12 B-2	N3/4"-12 D	06 520 004	15	M12	80	35	37-56	27	1.05
60	ISO 12 B-2	N3/4"-20 D	06 520 005	15	M20	120	165	50-90	38	1.35
80	ISO 16 B-2	N1"-20 D	06 520 006	13	M20	120	165	55-84	38	2.10
100	ISO 20 B-2	N1 1/4"-20 D	06 520 007	13	M20	140	165	60-102 / 68-102	45 / 50	3.60
120	ISO 24 B-2	N1 1/2"-20 D	06 520 008	11	M20	140	165	65-97 / 73-97	45 / 50	4.25
Triplex "T"										
35	ISO 06 B-3	N3/8"-10 T	06 530 001	15	M10	70	20	33-48	18	0.25
40	ISO 08 B-3	N1/2"-12 T	06 530 002	15	M12	80	35	41-51	27	0.50
50	ISO 10 B-3	N5/8"-12 T	06 530 003	15	M12	80	35	43-50	27	0.95
50	ISO 10 B-3	N5/8"-20 T	06 530 004	15	M20	120	165	56-84	38	1.25
60	ISO 12 B-3	N3/4"-20 T	06 530 005	15	M20	120	165	59-80	38	1.50
80	ISO 16 B-3	N1"-20 T	06 530 006	13	M20	160	165	74-108	45	2.90
100	ISO 20 B-3	N1 1/4"-20 T	06 530 007	13	M20	160	165	78-105 / 86-105	45 / 50	5.20
120	ISO 24 B-3	N1 1/2"-20 T	06 530 008	11	M20	180	165	90-111 / 98-111	45 / 50	6.20

Sprocket wheel type N

Roller chain		Type	Art. No.	Number of teeth	A	B	C	D	Weight [kg]
ANSI	DIN 8187								
35	ISO 06 B	N3/8"-10	06 500 001	15	10	5.3	9	45.81	0.06
40	ISO 08 B	N1/2"-10	06 500 002	15	10	7.2	9	61.08	0.15
40	ISO 08 B	N1/2"-12	06 500 003	15	12	7.2	12	61.08	0.15
50	ISO 10 B	N5/8"-12	06 500 004	15	12	9.1	12	76.36	0.27
50	ISO 10 B	N5/8"-20	06 500 005	15	20	9.1	15	76.36	0.29
60	ISO 12 B	N3/4"-12	06 500 006	15	12	11.1	12	91.63	0.47
60	ISO 12 B	N3/4"-20	06 500 007	15	20	11.1	15	91.63	0.47
80	ISO 16 B	N1"-20	06 500 008	13	20	16.1	15	106.14	0.88
100	ISO 20 B	N1 1/4"-20	06 500 009	13	20	18.5	15	132.67	1.60
120	ISO 24 B	N1 1/2"-20	06 500 010	11	20	24.1	15	135.23	1.93

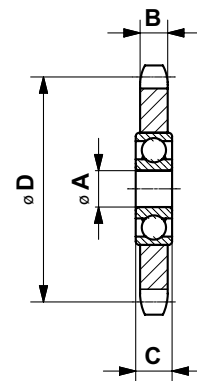

Chain Drives

Chain rider set type P

Chain rider type P

For an ideal positioning of the chain rider/s on the threaded rod we do recommend to position them on each side by means of two nuts, secured against each other, with some play for swivelling into working position.

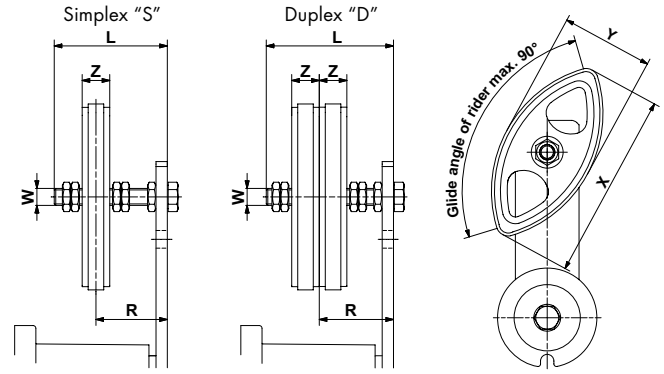

Chain rider set type P

Roller chain ANSI DIN 8187		Type	Art. No.	W	L	X	Y	Z	Torque hex nut 0.5d [Nm]	Adjusting range track R	Size SE	Weight [kg]
Simplex "S"												
35	ISO 06 B-1	P3/8"-8 S	06 550 001	M8	45	74	37	10.2	11	19-34	11	0.05
40	ISO 08 B-1	P1/2"-10 S	06 550 002	M10	55	96	48	13.9	20	23-41	15/18	0.10
50	ISO 10 B-1	P5/8"-10 S	06 550 003	M10	55	126	63	16.6	20	24-39	18	0.12
60	ISO 12 B-1	P3/4"-12 S	06 550 004	M12	80	148	72	19.5	35	30-61	27	0.18
Duplex "D"												
35	ISO 06 B-2	P3/8"-8 D	06 560 001	M8	45	74	37	10.2	11	25-30	11	0.07
40	ISO 08 B-2	P1/2"-10 D	06 560 002	M10	55	96	48	13.9	20	30-34	15/18	0.12
50	ISO 10 B-2	P5/8"-10 D	06 560 003	M10	70	126	63	16.6	20	34-46	18	0.17
60	ISO 12 B-2	P3/4"-12 D	06 560 004	M12	80	148	72	19.5	35	40-52	27	0.26

Chain rider type P

Roller chain ANSI DIN 8187		Type	Art. No.	A ^{+0.2} ₀	B	C	D	Weight [kg]
35	ISO 06 B	P3/8"	06 540 001	8	10.2	37	74	0.02
40	ISO 08 B	P1/2"	06 540 002	10	13.9	48	96	0.03
50	ISO 10 B	P5/8"	06 540 003	10	16.6	63	126	0.05
60	ISO 12 B	P3/4"	06 540 004	12	19.5	72	148	0.07

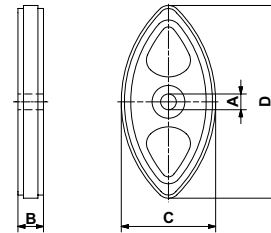

Mounting instructions for Chain Drives

See also complementary mounting instructions on page 4.5.

Standard positioning

The ROSTA tensioning device should be placed on the slack-side of the chain drive, close by the smaller sprocket wheel in order to enlarge its contact-arc, therefore contact application from outer side of drive. In mounted position the tensioner-arm should stay close to parallel to the chain run, in drain direction. By extremely long chain drives it is recommendable to install several tensioners or the type "Boomerang®" in order to enlarge the slack compensation.

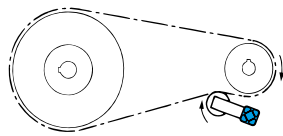

Reversible chain drive

By reversible chain transmissions it is recommendable to install a tensioner on each side of the chain-strands. Due to the alternate occurring of the slack, both tensioners should only be pre-tensioned up to max. 20°, in order to retain a reset-path of 10°, when strains are changing from slack span on working span in reversible applications.

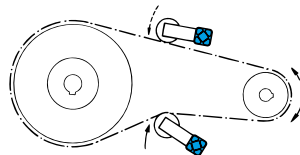

Sprocket teeth in mesh

By the initial tensioning of the chain at least three teeth of the tensioner sprocket wheel should be in mesh with the rollers. The min. distance between sprocket wheel of the tensioner to the next sprocket wheel in the chain drive should be at least four chain-pitches.

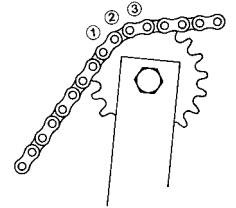

Adjustment of chain-track

The wheel of the sprocket wheel set is adjustable according to the position of the chain drive track. The wheel is positioned between two nuts on the threaded shaft. In changing the adjustment band "R", the track of the tensioner wheel can be set according to relevant strand course. After positioning of sprocket, re-tighten the two nuts on the side. The counter-nut "B" remains always tightened.

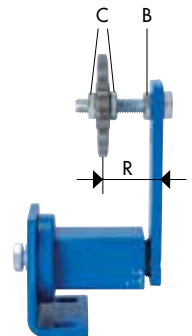

Accessories belt drives

Tensioning roller Type R and RL

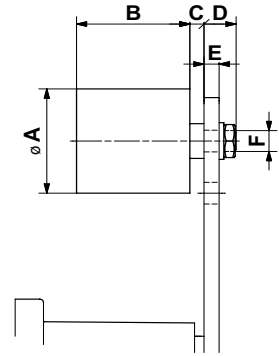

Tensioning roller standard type R (blue)

Type	Art. No.	Max. speed [rpm]	Max. belt width	A	B	C	D	E max.	F	Torque hex nut [Nm]	Size SE	Weight [kg]
R 11	06 580 001	8000	30	30	35	2	14	5	M8	25	11	0.08
R 15/18	06 580 002	8000	40	40	45	6	16	7	M10	20	15/18	0.17
R 27	06 580 003	6000	55	60	60	8	17	8	M12	35	27	0.40
R 38	06 580 004	5000	85	80	90	8	25	10	M20	165	38	1.15
R 45	06 580 005	4500	130	90	135	10	27	12	M20	165	45	1.75

Tensioning roller light type RL (black). Designed for light-duty drives.

Type	Art. No.	Max. speed [rpm]	Max. belt width	A	B	C	D	E max.	F	Torque hex nut [Nm]	Size SE	Weight [kg]
new RL 11	06 580 901	6000	30	30	35	3	19	10	M8	25	11	0.08
new RL 15/18	06 580 902	6000	40	40	45	6	21	9	M10	49	15/18	0.17
new RL 27	06 580 903	4500	55	60	60	8	22	8	M12	86	27	0.50

Instructions for belt drives

a) Modalities of tensioning

See also complementary mounting instructions on page 4.5.

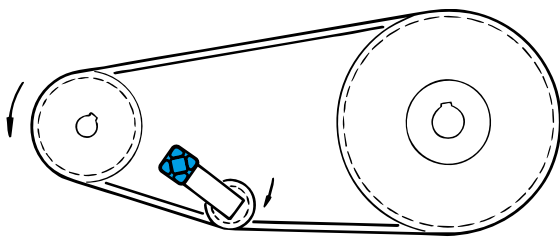

Tensioning from "inside" of the belt drive with grooved pulley

- Installation in slack span of the belt drive, make sure that the belts are maintaining sufficient contact-arc on the driver- and driven-pulley.
- By extremely long centre distances between driver and driven pulley it is recommendable to use on the tensioner a deep-grooved pulley to avoid excessive slack beating.

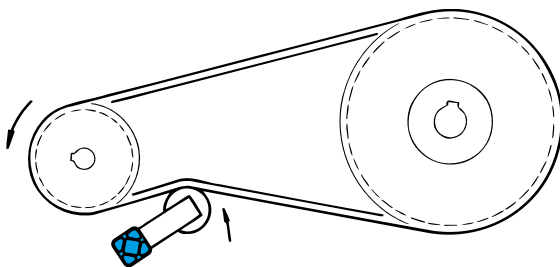

Tensioning with flat roller on belt back

- The diameter of the flat tensioning roller should at least measure $\frac{2}{3}$ of the diameter of the smallest pulley in the drive.
- The width of the tensioning roller should be at least 20% wider than the overall width of the belt set.
- Installation on the belt back in the slack span, make sure that the belts are maintaining sufficient contact-arc on the driver and driven pulley.

b) Selection of the adequate ROSTA Tensioner size

Selection table mentioning the most conventional V-belt types.

V-belt type	Width [mm]	Height [mm]	Diam. of smaller pulley [mm]	Initial operation test-force F_1^{**} [N]	Operational test-force F_0^{**} [N]	Size SE* (without SE-W, SE-B and SE-FE)				
						1 belt	2 belts	3 belts	4 belts	5 belts
XPZ, SPZ	10	8	56-71	20	16	11	18	18	18	18
			75-90	22	18	11	18	18	18	27
			95-125	25	20	15	18	18	18	27
			≥ 125	28	22	15	18	18	27	27
XPA, SPA	13	10	80-100	28	22	15	18	18	27	27
			106-140	38	30	15	18	27	27	27
			150-200	45	36	18	18	27	27	27
			≥ 200	50	40	18	18	27	27	38
XPB, SPB	16	13	112-160	50	40	18	18	27	27	38
			170-224	62	50	18	27	27	38	38
			236-355	77	62	18	27	38	38	38
			≥ 355	81	65	18	27	38	38	38
XPC, SPC	22	18	224-250	87	70	18	27	38	38	38
			265-355	115	92	27	38	38	45	45
			≥ 375	144	115	27	38	38	45	45
Z	10	6	56-100	5-7.5		11	11	11	15	15
A	13	8	80-140	10-15		11	15	18	18	18
B	17	10	125-200	20-30		15	18	18	27	27
C	22	12	200-400	40-60		18	27	27	38	38
D	32	19	355-600	70-105		18	27	38	38	45

* General basic selection criteria:

F resulting tensioning force by a pre-tension angle of 20° (see table page 4.5)

F_1 initial operation test-force according guidelines of the belt manufacturer

z quantity of belts in drive

2 multiplier for the compensation of belt-slippage and/or of centrifugal force generated on belt strands.

$$F = F_1 \cdot z \cdot 2$$

** required test-force for belt deflection of 16 mm per 1000 mm of centre distance.

The relevant deflection by shorter or longer centre distance has to be interpolated accordingly.

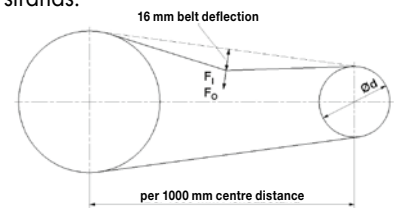

c) Control procedure for checking belt tension

Proceed according to the mentioned guidelines on page 4.5 and 4.10-4.11.

There are several instruments for checking with the adequate test-force the right tension on your frictional V-belt drive.

Don't make it with your thumb, you will make an estimation mistake and your belts will wear out prematurely!



Optikrik-tester from **Optibelt**



Spring scale tester from **Gates**



Infrared-frequency tester

Re-tension of belts: Generally, there is no re-tension maintenance service required, however we would recommend to check the test-force after some days of running-in with the required operational test-force (see table above).

ROSTA Tensioner Devices and Accessories to meet individual customer requirements



Support bracket type WS

For the easy mounting of all standardized ROSTA Tensioners (except SE 50).

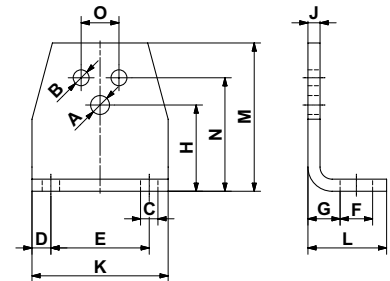

Type	Art. No.	suitable to Size SE	A	B	C	D	E	F	G	H	J	K	L	M	N	O	Weight [kg]
WS 11	06 590 001	11	6.5	5.5	7	7.5	30	13	11.5	27	4	45	30	46	35	10	0.08
WS 15	06 590 002	15	8.5	6.5	7	7.5	40	13	13.5	34	5	55	32	58	44	12	0.15
WS 18	06 590 003	18	10.5	8.5	9.5	10	50	15.5	16.5	43	6	70	38	74	55	20	0.28
WS 27	06 590 004	27	12.5	10.5	11.5	12.5	65	21.5	21	57	8	90	52	98	75	25	0.70
WS 38	06 590 005	38	16.5	12.5	14	15	80	24	21	66	8	110	55	116	85	35	0.90
WS 45	06 590 006	45	20.5	12.5	18	20	100	30	26	80	10	140	66	140	110	40	1.80

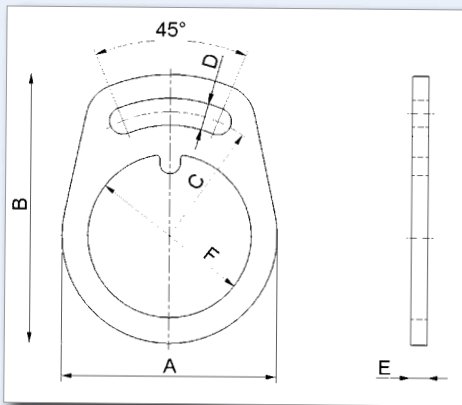

Safety Sockets SS 27 and SS 38

By uneven surfaces and/or by paint coatings, which are giving insufficient friction locking, the positioning and further re-tensioning can be made with these standardized Safety Sockets.



Type	Art. No.	suitable to Size SE	A	B	C	D	E	F	Weight [kg]
SS 27	06 618 400	27	104	130	60	13	8	79	0.35
SS 38	06 618 394	38	128	161	75	17	10	96.5	0.65

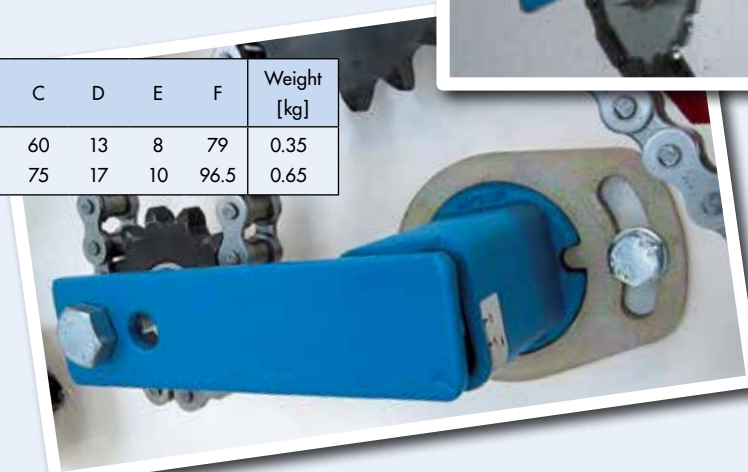

www.rosta.com

Guide roller suspensions with tensioners SE and pre-tensioning devices VS

For the accurate definition of the required pre-tension and limitation of the roller travel we do recommend the use of our pre-tensioning clamp VS allowing angle adjustments from 0–15° (for all SE-sizes available).

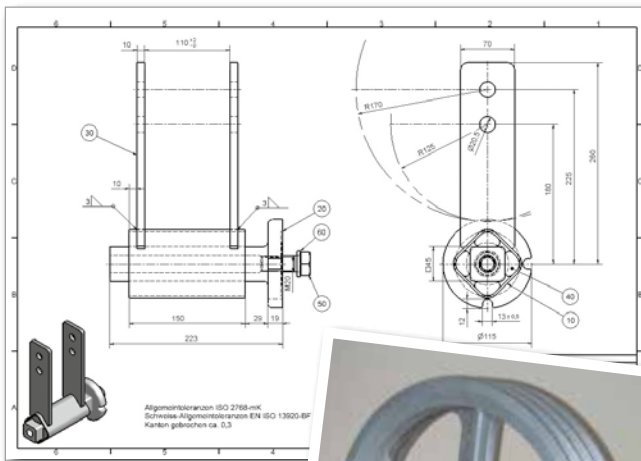
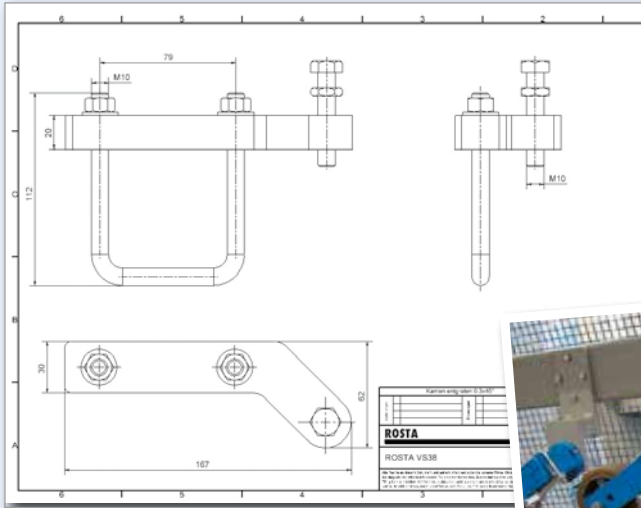

DAT (Double Arm Tensioner)

For the transfer of very high tension-forces we do recommend to use double arm tensioners, avoiding any misalignment or fault of parallelism between tensioner housing and inner square-core-generating belt eating angular off-set of the tensioning pulley.



Elastic suspension of conveyor belt scrapers with tensioner devices SE

The ROSTA suspension is offering continuous and wear compensating cleaning pressure on conveyor belt scrapers to abrade small particle sizes.

For belt widths:

- 400–600 mm = 2 units **SE 18**
- 600–800 mm = 2 units **SE 27**
- 800–1000 mm = 2 units **SE 38**
- 1000–1300 mm = 2 units **SE 45**

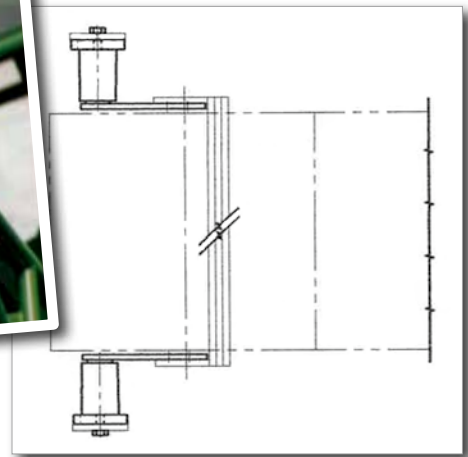
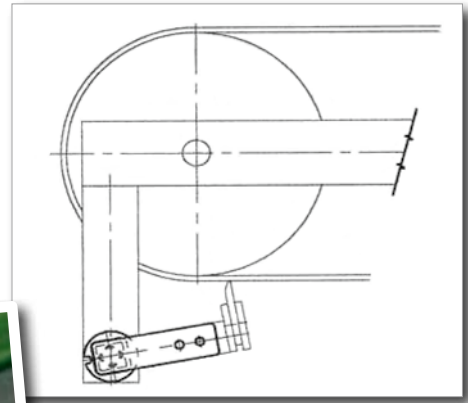

Heavy-Duty belt and chain tensioners made out of Motorbase components

The ROSTA Motorbase elements are offering extremely high torques to tension heaviest chains and oversized belt drives.

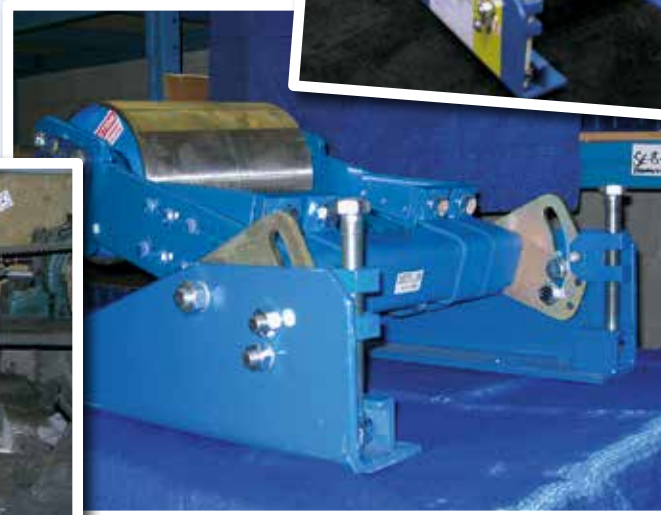

www.rosta.com

Strained Applications!

A few examples:



Tensioner Devices



ROSTA 

联系人：刘先生

手机：13812944164

固话：0512-57702362

传真：0512-57711087

email: daqiang.liu@smc-sz.com.cn

T2018.956